

INTERMITTORE / OSCILLATORE
INTERMITTENT / OSCILLATING DRIVE

IT 55 / OT 55

PESO / Weight

Fusione in ghisa / Cast iron box kg.143

Fusione in alluminio / Aluminum box kg. 78

DISPONIBILE SU DISCO CAD
 Available on CAD disc

FILE
 W41609

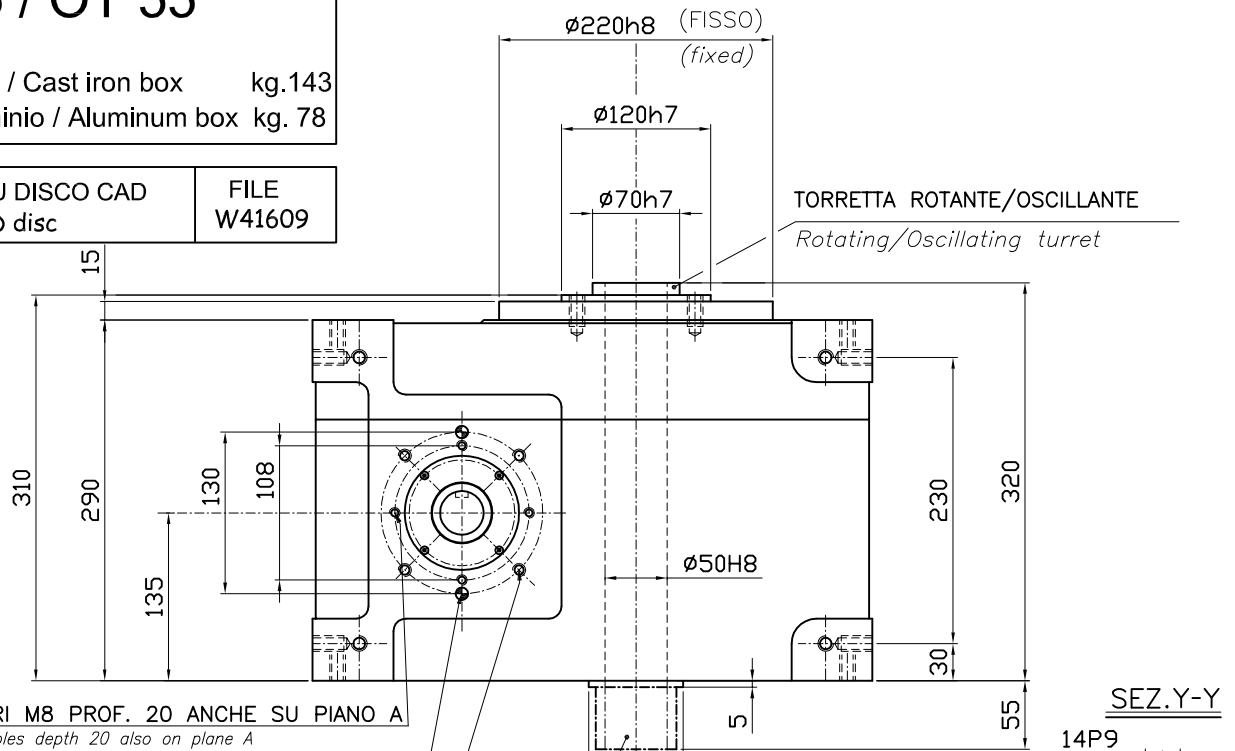

N°4 FORI M8 PROF. 20 ANCHE SU PIANO A

N°4 M8 holes depth 20 also on plane A

N°2 FORI 10H7 prof.=20 ANCHE SU PIANO A

N°2 holes i.d. 10H7 depth=20 on plane A too

N4 FORI M10 PROF. 24 ANCHE SU PIANO A

N°4 M10 holes depth 24 also on plane A

ALBERO SPORGENTE
 ROTANTE/OSCILLANTE (SU RICHIESTA)

Rotating/Oscillating turret shaft extension
 (on request)

SEZ. Y-Y

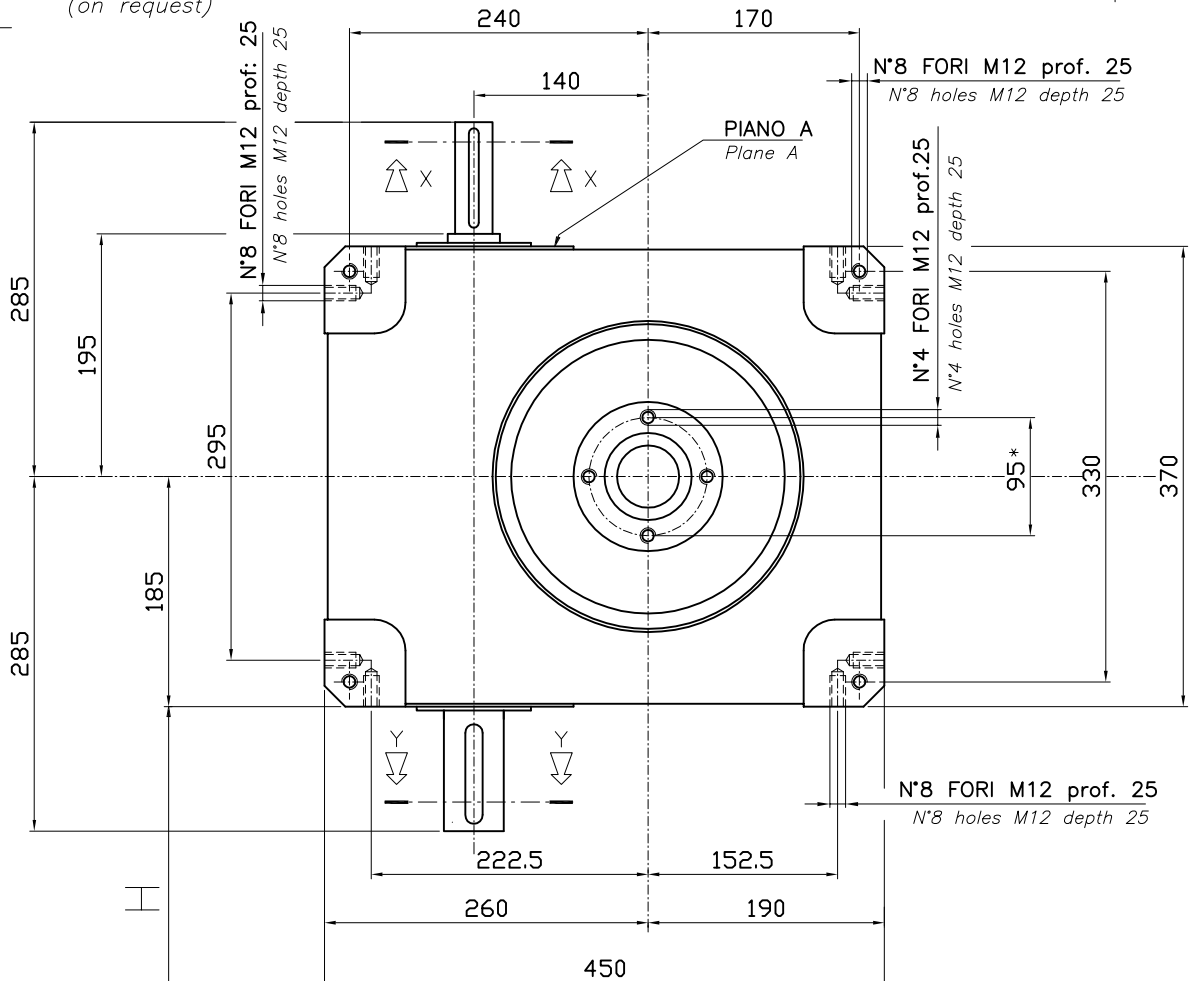
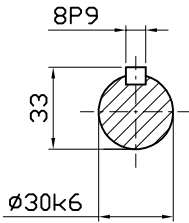
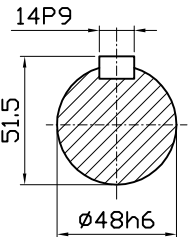

DISTANZA ASSE
 UNITA' MOTRICE

Power drive unit C.L. distance

(VEDI CATALOGO)

(See catalogue)

*FORATURA CONSIGLIATA. ESECUZIONE SU RICHIESTA.
 Suggested diameter for threaded holes.
 Machined on request.